

DigiTrace TCONTROL-CONT-02

Compact microprocessor controller

Operating Manual

BR 70.3011/1

11.03/



Please read this Manual carefully before starting up the instrument. Keep this Manual in a place which is at all times accessible to all users. Please assist us to improve this Manual where necessary. Your suggestions will be most welcome.



All necessary settings are described in this Operating Manual. If any difficulties should still arise during start-up, you are asked not to carry out any manipulations on the unit which are not permitted. You could endanger your rights under the warranty. Please contact the nearest office or the main factory.



When returning chassis, assemblies or components, the rules of EN 100 015 "Protection of electrostatically endangered components" have to be observed. Use only the appropriate ESD packaging material for transport.

Please note that we can not be held liable for any damages caused by ESD (electrostatic discharges).

Default Settings

Parameter level	Page
AI 1	26, 41
AI 2	26, 41
Pb 1	22, 41
Pb 2 ^a	22, 41
dt	22, 41
rt	22, 41
Cy 1	22, 41
Cy 2 ¹	22, 41
db	23, 41
HYS 1	23, 41
HYS 2 ¹	23, 41
Y0	23, 41
Y1	24, 41
Y2	24, 41
dF	16, 41
rASd	31, 41



PGM
>2sec

Configuration level	Page
C111	16, 20, 27, 37
C112	26, 27, 29, 38
C113	24, 28, 31, 39
C114	
SCL	17, 40
SCH	17, 40
SPL	18, 40
SPH	18, 40
OFFS	17, 40
HySt	26, 40



PGM
>2sec

■ = factory setting

- a. This parameter appears only if a double setpoint controller has been configured as controller type.

Contents

1	Description	4
2	TCONTROL-CONT-02 Factory Settings	5
3	Installation	6
3.1	Dimensions	6
3.2	Fitting in position and removing the controller chassis	7
3.3	Cleaning the front panel	7
4	Electrical connection	8
4.1	Notes on installation	8
4.2	Connection diagram	10
5	Operation	11
5.1	Displays and keys	11
5.2	Principle of operation	12
5.3	Entering setpoints and parameters	14
5.4	Entering the configuration codes	14

Contents

6	Configuration	15
6.1	Process value input	16
6.2	Setpoint limits	18
6.3	Logic inputs	19
6.4	Controller	21
6.5	Limit comparators	25
6.6	Outputs	27
6.7	Display	29
6.8	Ramp function	30
6.9	Programme controller	32
6.10	Self-optimisation	35
7	Appendix	37
7.1	Configuration code and parameter tables	37
7.2	Alarm messages	42
7.3	Technical data	43

1 Description

- Programmable single/double setpoint controller or proportional controller with PID structure.
- Self-optimisation
- Ramp function
- Programme function
- Programmable input filter
- 1 limit comparator
- 2 setpoints with setpoint switching
- 2 parameter sets with parameter set switching

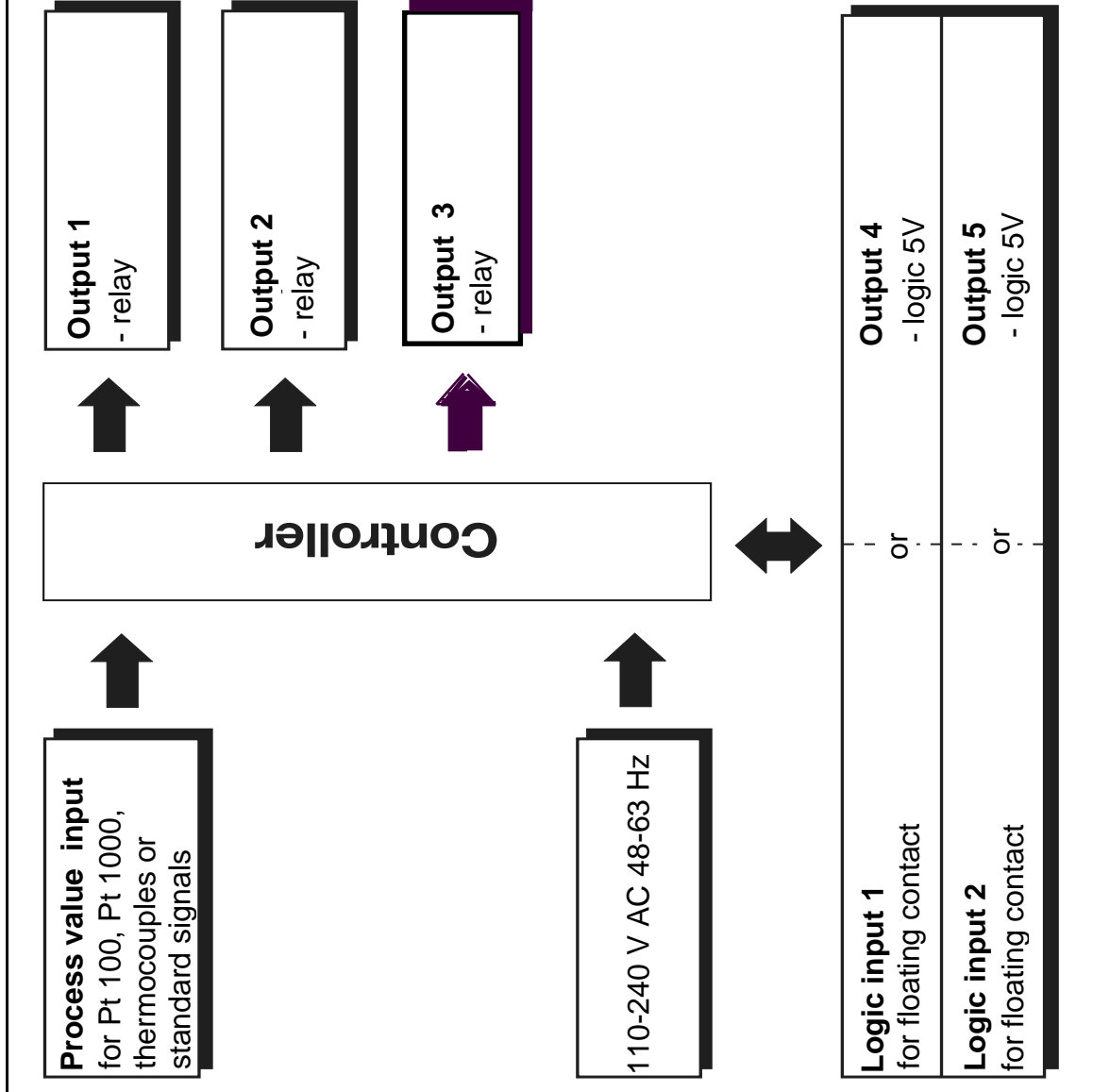

2 TCONTROL-CONT-02 Factory Settings

Control Mode:	O function for process heating
Input:	Pt100 (3 wire)
Output Relay K1	Control Output (setpoint 5°C, hysteresis 2)
Relay K2	Alarm (Limit Comparator) (set as low temperatur alarm 2° C, hysteresis 0)
Relay K3	Alarm (limit comparator) (set as high temperature alarm 80°C, hysteresis 0)
Supply Voltage	110 - 240 V + 10/-15 % AC 48 - 63 Hz

Alarms	See Section 6.5
Limit Comparators	lk1 — lk8

Delivery package:

- controller
- 1 seal
- 1 mounting frame
- Operating Manual BR 70.3011

Software Selectable Settings

Control Funktion	See Section 6.4
Single Control	O Funktion on/off
Single Control	S Funktion on/off
PID Control	
Process value Input	See Section 6.1
Pt 100	Linearised transducers
Pt 1000	4 - 20mA
Fe-Con J	
Cu-Con U	
Fe-Con L	
NiCr-Ni K	

3 Installation

3.1 Dimensions

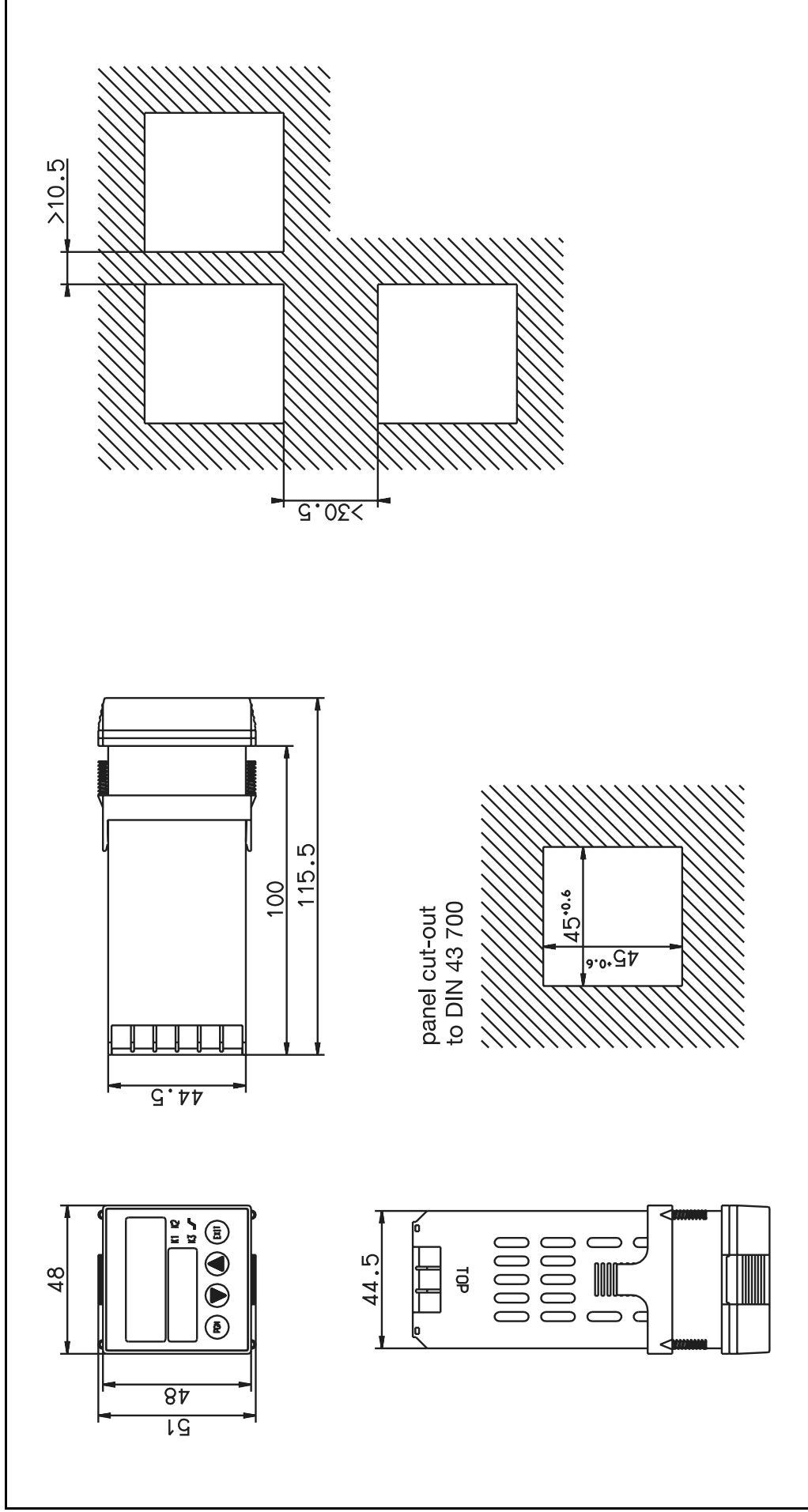

3.2 Fitting in position and removing the controller chassis

- * Fit the seal provided onto the instrument housing
- * Insert the controller from the front into the panel cut-out.
- * From the back of the panel, push the mounting frame onto the instrument housing and press it against the back of the panel, compressing the springs, until the latches snap into the notches provided and it is securely fixed in position.
- * Press together the knurled areas (top and bottom) on the front panel and pull out the controller chassis.

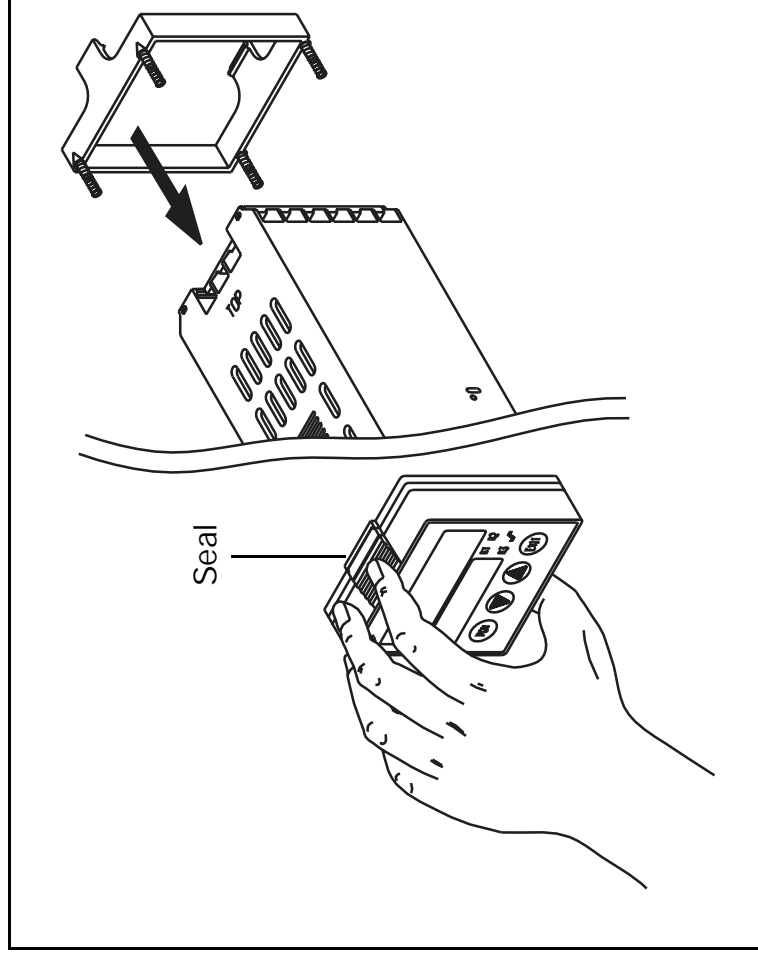

3.3 Cleaning the front panel

The front panel can be cleaned with the usual wash and rinse agents and cleaners. It has a limited degree of resistance to organic solvents (e. g. petrol, benzene, P1, xylene and similar). Do not use any high-pressure cleaners.

4 Electrical connection

4.1 Notes on installation

- The choice of cable, the installation and the electrical connection must conform to the requirements of VDE 0100 "Regulations on the Installation of Power Circuits with nominal voltages below 1000V" or the appropriate local regulations.
- The electrical connection must only be carried out by properly qualified personnel.
- If contact with live parts is possible when working on the instrument, it has to be isolated on both poles from the supply.
- A current limiting resistor interrupts the supply circuit in case of a short-circuit. The external fuse of the supply should not be rated above 1A (slow). The load circuit must be fused for the maximum relay current in order to prevent welding of the output relay contacts in case of an external short-circuit.
- Electromagnetic compatibility conforms to the standards and regulations listed under Technical Data.
- Run input, output and supply lines separately and not parallel to each other.

- Sensor and interface lines should be arranged as twisted and screened cables. Do not run them close to current-carrying components or cables.
- Do not connect any additional loads to the supply terminal of the instrument.
- The instrument is not suitable for installation in hazardous areas.
- Apart from faulty installation, there is a possibility of interference or damage to controlled processes due to incorrect settings on the controller (setpoint, data of parameter and configuration levels, internal adjustments). Safety devices independent of the controller, such as overpressure valves or temperature limiters/monitors, should always be provided and should be capable of adjustment only by specialist personnel. Please refer to the appropriate safety regulations in this connection. Since auto-tuning (self-optimisation) can not be expected to handle all possible control loops there is a theoretical possibility of unstable parameter settings. The resulting process value should therefore be monitored for its stability.

4.2 Connection diagram

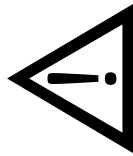

The electrical connection must only be made by properly qualified personnel.

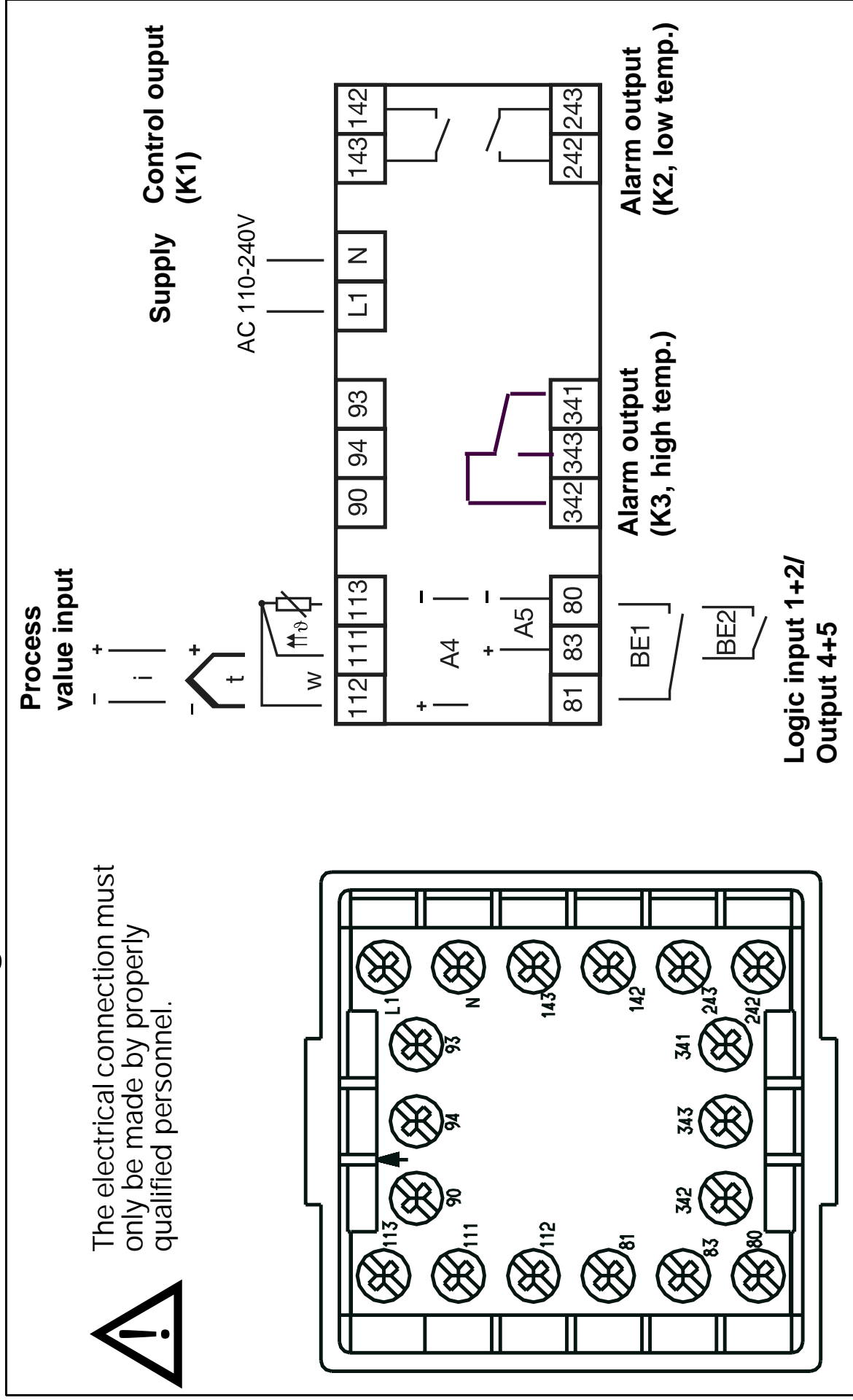

5 Operation

5.1 Displays and keys

(1)	Process value display red, 10mm, 4 digits
(2)	Setpoint display green, 7 mm, 4 digits
(3)	PGM key to select the parameters
(4)	Decrement key to alter values
(5)	Increment key to alter values
(6)	EXIT key to quit the levels
(7)	LED for ramp/programme function lights up when configured; green
(8)	LED for status indication for outputs 1 to 3; yellow

The diagram shows a control panel with two digital displays. The top display (1) shows the value '299.5' and the bottom display (2) shows '300.0'. Below the displays are four keys: a circular 'PGM' key (3), a downward-pointing triangle key (4), an upward-pointing triangle key (5), and a circular 'EXIT' key (6). To the right of the keys are two LEDs: a green one (7) and a yellow one (8). The displays are labeled with (1) and (2) respectively. The keys are labeled with (3), (4), (5), and (6). The LEDs are labeled with (7) and (8).

5.2 Principle of operation

Generally, the following applies:

- * Change to the next level with **PGM**
(Press key for at least 2 sec!)
- * Change to the next parameter with **PGM**
- * Return to standard display with **EXIT**

Standard display

The displays show the process value and the active setpoint or the programme/ramp setpoint. The active setpoint can be changed here.

⇒ Section 5.3

Operating level

Here the setpoints SP1 and SP2 are input and the profile segments of the programme function are programmed (if the programme function is configured).

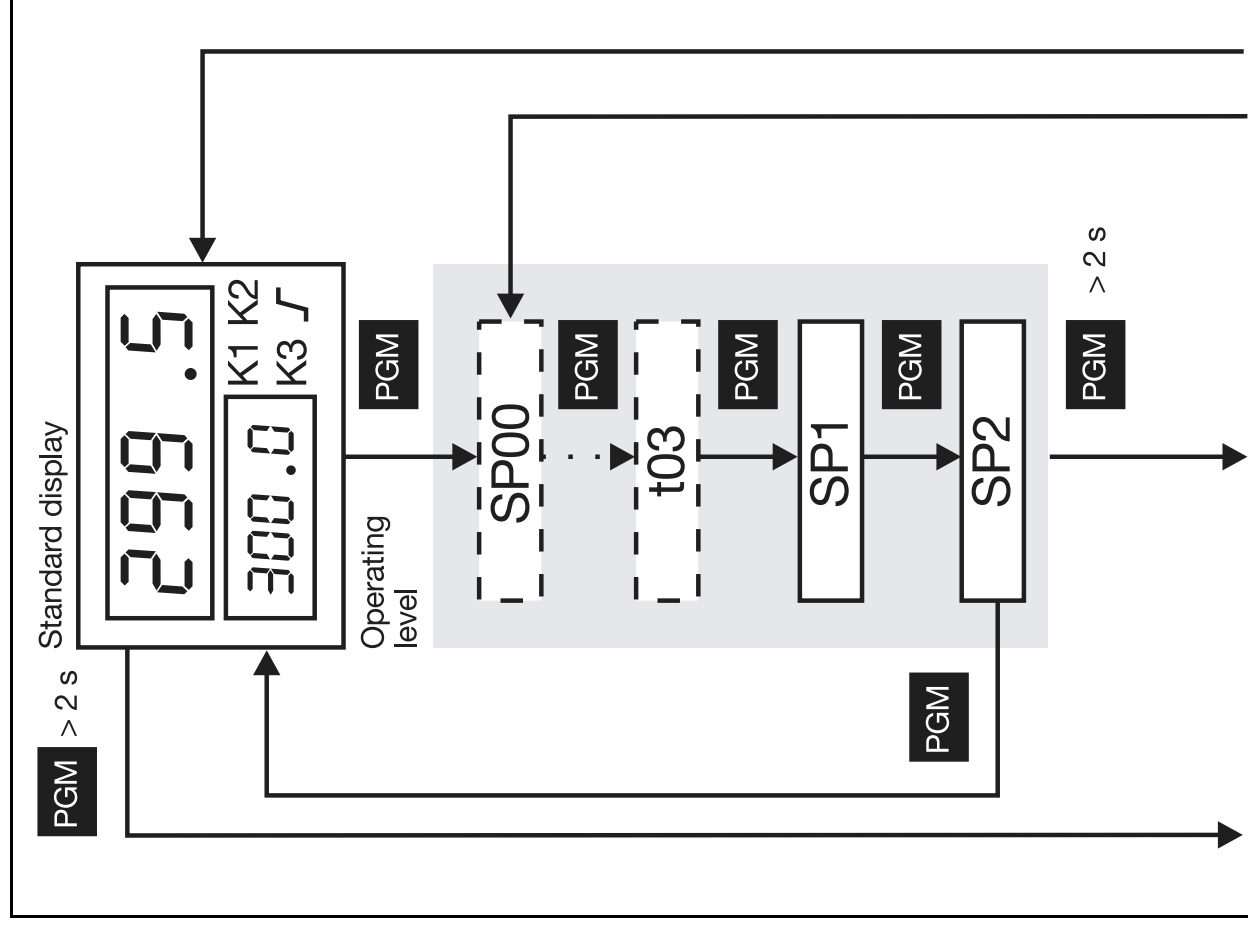

Parameter level

The limit values of the limit comparators and the controller parameters are programmed here. The instrument has two parameter sets. Display switching of the parameter sets is via parameter Pb.1.

⇒ Section 6.4

Configuration level

The basic functions of the controller are set here. Settings can only be made after leaving the parameter level via the y.0 parameter.

Time-out

If no operation occurs, the controller returns automatically to standard display after approx. 30 sec.

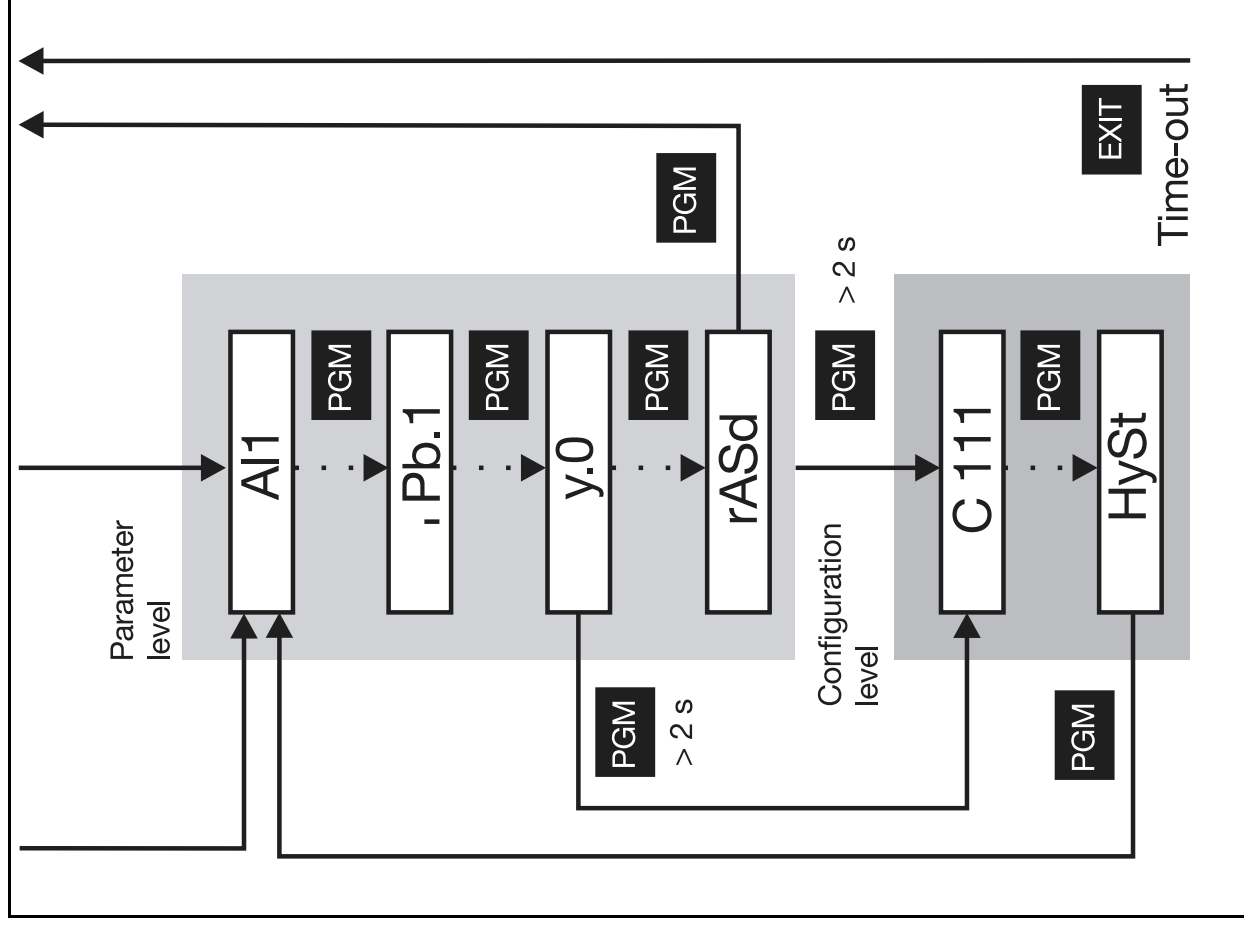

5.3 Entering setpoints and parameters

Parameters and setpoints are input and altered by continually altering the value. The change speeds up the longer the key is held down.

- * Increase the setpoint (parameter) with **▲**
- * Decrease the setpoint (parameter) with **▼**

The setpoint (parameter) is accepted automatically after approx. 2 sec; display flashes briefly

The value alters only within the permitted range of values.

⇒ Section 6.2 (setpoint limits)

5.4 Entering the configuration codes

- * Select the digit with **▼** (digit flashes!)
- * Alter the value with **▲**
- * Confirm the code with **PGM**
or
abort the input with **EXIT**

Example: Altering the setpoint
in standard display

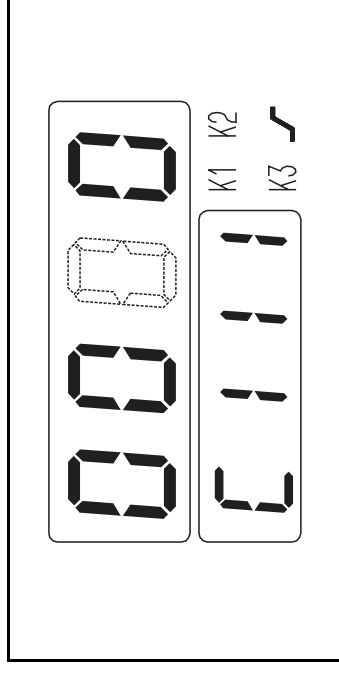
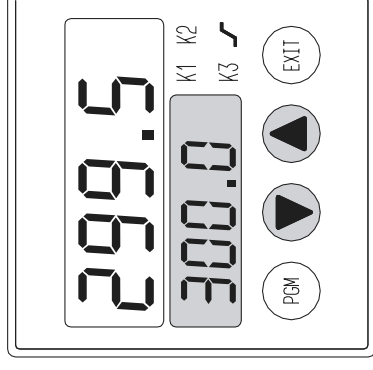

6 Configuration

The following sections describe the functions of the instrument with their relevant parameters and settings.

The parameter and the configuration codes are listed in the sequence in which they appear within the level structure. The following procedure is however recommended:

- * Familiarise yourself with the controller functions
- * Enter the parameter values and the configuration codes in the table provided for this purpose on the back cover. The parameters and configuration codes are listed in the order of their appearance.
- * Enter the parameters and configuration codes into the instrument

Presentation

The configuration codes have 4 positions. For functionally relevant positions, the kind of function and its selection possibility is described in the appropriate column. Positions which are not relevant for the function are marked with an "X" in the column.



For the experienced user, the parameters and configuration codes are summarised in the tables which are provided in the Appendix.

⇒ Section 7.1

6.1 Process value input

The process variable is fed into the controller via the process value input.

Parameter	Value range	factory-set	Notes
dF	0.0—100.0 sec	0.6 sec	Filter time constant to adapt the digital input filter (0 sec = filter off)

C111	Transducer		X	X	X
	Pt 100	0			
	Pt 1000	1			
	Fe-Con L	2			
	NiCr-Ni K	3			
	Pt10Rh-Pt S	4			
	Pt13Rh-Pt R	5			
	Pt30Rh-Pt B	6			
	Cu-Con U	7			
	NiCrSi-NiSi N	8			
	Fe-Con J	9			
	Standard signal 0 — 20mA	A			
	Standard signal 4 — 20mA	b			

■ = factory setting X = position functionally not relevant

Parameter	Value range	factory-set	Notes
SCL	-1999 to +9999 digit ¹	-50	Start/end of value range for standard signals Example: 0—20 mA→20—200 °C: SCL = 20 /SCH = 200
SCH	-1999 to +9999 digit ¹	250	
OFFS	-1999 to +9999 digit ¹	0	SCL and SCH are simultaneously the calibration for the process value output ⇨ Section 6.6 Process value correction (offset) The offset can be used to correct the measured value by a certain amount up or down. Examples: Measured value Offset Displayed value 294.7 + 0.3 295.0 295.3 - 0.3 295.0

1. On a display with one or two decimal places the value range and the factory setting change accordingly (e. g. 1 decimal place → value range: -199.9 to +999.9).

6.2 Setpoint limits

Parameter	Value range	factory-set	Notes
SPL	-1999 to +9999 digit ¹	-40	Display start/end with external setpoint input. Low/high setpoint limit for SP1 and SP2. Example: 4 — 20mA → 0 — 250 °C; SPL = 0, SPH = 250 Setpoint limits Setpoint inputs below or above these limits are not accepted. The value of SPL / SPH flashes on the display.
SPH	-1999 to +9999 digit ¹	600	

1. On displays with one or two decimal places the value range and the factory setting change accordingly (e. g. 1 decimal place → value range: -199.9 to +999.9).

6.3 Logic inputs

Various operating functions can be activated via the two logic inputs.

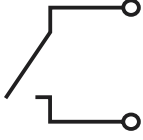
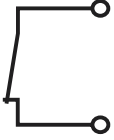
		
Key inhibit	Operation is possible by keys	No operation by keys
Level inhibit	Access possible to parameter and configuration level. Start of self-optimisation is possible.	No access to parameter and configuration level No start of self-optimisation
Programme/ ramp stop	Programme/ramp running (when configured!)	Programme/ramp stopped
Programme/ ramp start	-	Programme/ramp (re)started
Setpoint switching	Setpoint SP1 is activated.	Setpoint SP2 is activated.
Parameter set switching	Parameter set 1 is activated. (, P _{b. i})	Parameter set 2 is activated. (, P _{b. i})
Enabling the limit comparators	Limit comparators are off.	Limit comparators are activated.

C111

Logic inputs 1 (BE1) and 2 (BE2)	X	X	BE1	BE2
no function			0	0
Key inhibit			1	1
Level inhibit			2	2
Programme/ramp stop			3	3
Programme/ramp start			4	4
Setpoint switching			5	5
Parameter set switching			6	6
Enabling limit comparators			7	7

■ = factory setting X = position functionally not relevant



Different functions can be combined.

6.4 Controller

The controller type is set here, and the controller is adjusted to the process.

Controller functions

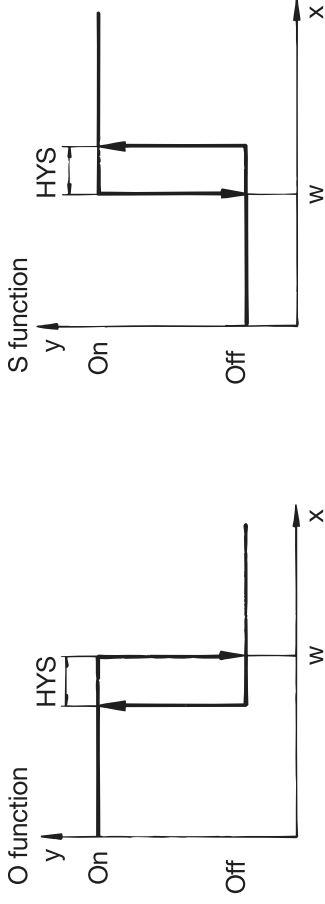

Selecting the parameter set

The controller has two parameter sets; a logic input can be used to switch between them. Both parameter sets can be displayed for setting the parameters.

- * Change between the display of the parameter sets with **PGM**, when parameter Pb.1 is displayed (hold key down for at least 2 sec!).

The parameter set which is displayed is shown by lit-up segments on parameter Pb.1.

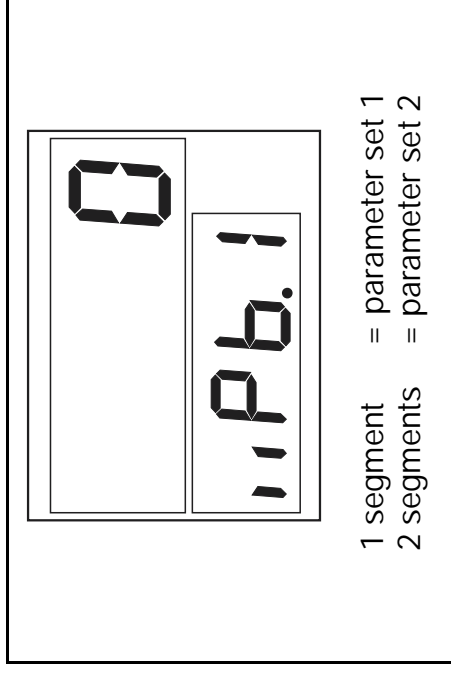

Controller structure

The controller structure is defined through parameters Pb, dt and rt.

Example: PI → Pb≠0, dt=0, rt≠0

Parameter	Value range	factory-set	Notes
Pb 1	0—9999 digit ¹	0	Proportional band 1 (controller output 1) Proportional band 2 (controller output 2) Influences the P action of the controller If Pb = 0, the controller structure is ineffective.
Pb 2	0—9999 digit ¹	0	
dt	0—9999 sec	80 sec	Derivative time Influences the D action of the controller. If dt=0, the controller has no D action.
rt	0—9999 sec	350 sec	Reset time Influences the I action of the controller. If rt=0, the controller has no I action.
Cy 1	0.5—999.9 sec	20.0 sec	Duration of switching cycle 1 (controller output 1) Duration of switching cycle 2 (controller output 2) Duration of switching cycle on switching outputs. The cycle time should be selected so that the energy supply to the process is virtually continuous while the switching elements are not subject to excessive wear.
Cy 2	0.5—999.9 sec	20.0 sec	

1. On the display with one or two decimal places the value range and the factory setting change accordingly (e. g. 1 decimal place → value range: -199.9 to +999.9).

Parameter	Value range	factory-set	Notes
db	0 — 1000 digit ¹	0.0	<p>Contact spacing For switching double-setpoint controllers</p>
HYS 1	0 — 9999 digit ¹	1.0	<p>Differential 1 (controller output 1) Differential 2 (controller output 2) For controllers with Pb=0</p>
HYS 2	0 — 9999 digit ¹	1.0	
Y0	-100 — 100%	0%	Working point Output at $x=w$

Parameter	Value range	factory-set	Notes
Y1	0—100%	100%	Maximum/minimum output Example: proportional controller with falling characteristic (indirect action)
Y2	-100 to +100%	-100%	

On controllers without controller structure (Pb=0) it is necessary that Y1 = 100% and Y2 = -100%

Controller type		X	X	X
Single-setpoint controller O function	0			
Single-setpoint controller S function	1			
Double-setpoint controller	2			
Proportional controller with falling characteristic (indirect action)	3			
Proportional controller with rising characteristic (direct action)	4			

C113

■ = factory setting X = position functionally not relevant

1. On the display with one or two decimal places the value range and the factory setting change accordingly (e. g. 1 decimal place → value range: -199.9 to +999.9).

6.5 Limit comparators

The measurements of the two inputs can be monitored with reference to the setpoint or a fixed value using two limit comparators.

Functions of the limit comparators

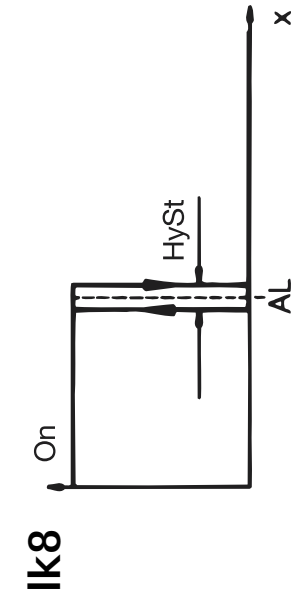
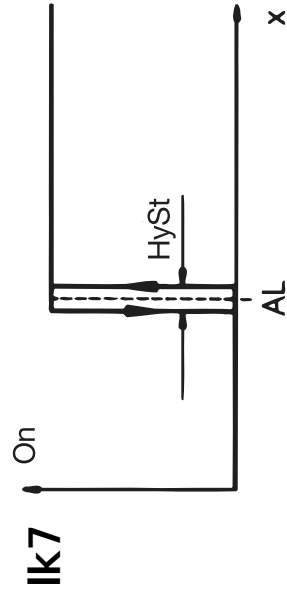
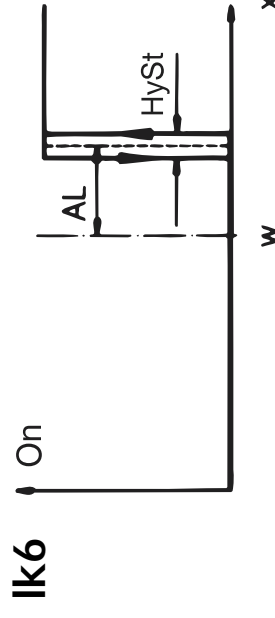
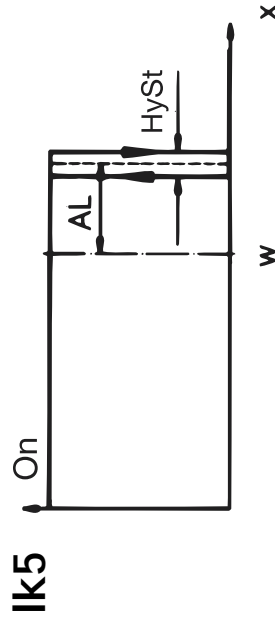
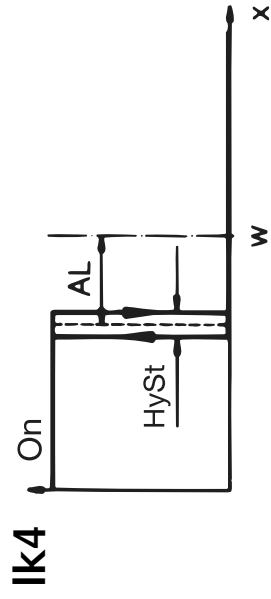
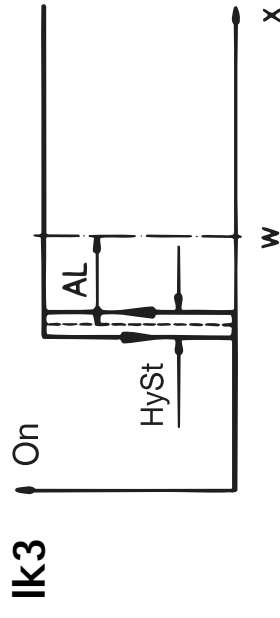
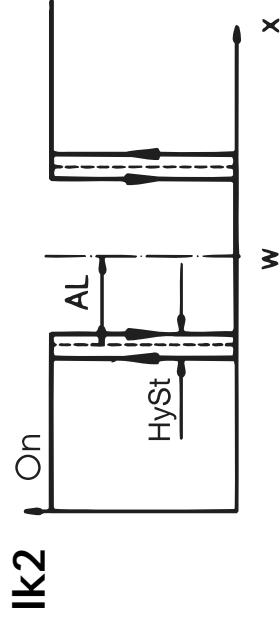
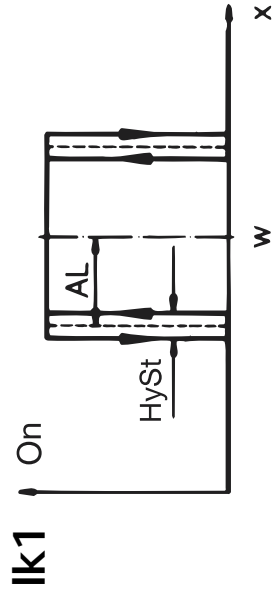

Ik1 — Ik6: Monitoring referred to the setpoint
 Ik7 / Ik8: Monitoring referred to a fixed value AL.

Parameter	Value range	factory-set	Notes
AL 1	-1999 to +9999 digit ¹	2	Limit limit comparator 1
AL 2	-1999 to +9999 digit ¹	80	Limit limit comparator 2

C112 Limit comparator 1 (LK1) and 2 (LK2)

	LK1	LK2	X	X
no function	0	0		
lk 1 (process value input)	1	1		
lk 2 (process value input)	2	2		
lk 3 (process value input)	3	3		
lk 4 (process value input)	4	4		
lk 5 (process value input)	5	5		
lk 6 (process value input)	6	6		
lk 7 (process value input)	7	7		
lk 8 (process value input)	8	8		

■ = factory setting

X = position functionally not relevant

Parameter	Value range	factory-set	Notes
HySt	-1999 to +9999 digit ¹	1	Switching differential of the limit comparators

1. In the display with one or two decimal places the value range and the factory setting change accordingly (e. g. 1 decimal place → value range: -199.9 to +999.9).

6.6 Outputs

The five outputs can be freely assigned to the functions.

C111	Output 4 (A4) and 5 (A5)	X	X	A4	A5
	no function			0	0
	Controller output 1			8	8
	Controller output 2			9	9
	Limit comparator output 1			A	A
	Limit comparator output 2			b	b
	Programme end			C	C

■ = factory setting X = position functionally not relevant

C112	Output signal on overrange	X	X	X	X
	Output 0%, limit comparators OFF				0
	Output 100%, limit comparators OFF				1
	Output -100%, limit comparators OFF				2
	Output 0%, limit comparators ON				3
	Output 100%, limit comparators ON				4
	Output -100%, limit comparators ON				5

■ = factory setting X = position functionally not relevant

C113

Output 1 (K1; relay) and 2 (K2; relay)	X	X	K1	K2
no function			0	0
Controller output 1			1	1
Controller output 2			2	2
Limit comparator output 1			3	3
Limit comparator output 2			4	4
Programme end			5	5

■ = factory setting X = position functionally not relevant

C114

Output 3 (K3)	X	X	X	K3
no function				0
Controller output 1 (function: 0 - 20mA/0 - 10V/switching)				1
Controller output 2 (function: 0 - 20mA/0 - 10 V/switching)				2
Limit comparator output 1 (function: switching)				3
Limit comparator output 2 (function: switching)				4
Programme end (function: switching)				5
Controller output 1 (function: 4 - 20 mA/2 - 10V)				6
Controller output 2 (function: 4 - 20 mA/2 - 10V)				7
Process value output (function: 0 - 20 mA/0 - 10V)				8
Process value output (function: 4 - 20 mA/2 - 10V)				9

■ = factory setting X = position functionally not relevant

6.7 Display

The number of the decimal places when displaying process value and setpoint in the standard display is defined here. In addition, the unit of the process value is determined.

C112	Decimal places/unit	X	X	X	X
	no decimal place, degree Celsius				
	one decimal place, degree Celsius				0
	two decimal places, degree Celsius				1 2
	no decimal place, degree Fahrenheit				3 4
	one decimal place, degree Fahrenheit				5
	two decimal places, degree Fahrenheit				

■ = factory setting X = position functionally not relevant

Displaying the unit and software version

- * Display the software version and unit of the process value with **PGM** + **▲** (hold keys down!)

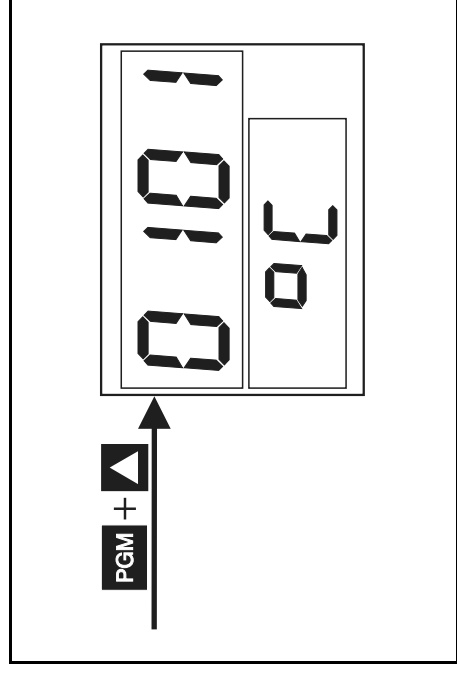

6.8 Ramp function

A rising or falling ramp function is possible. When the power is switched on, the ramp function starts with the current process value and the setpoint runs according to the selected gradient until the ramp end point SP is reached. The ramp end point is entered at the setpoint input (SP1, SP2). When the ramp end point is reached, then the ramp setpoint is equal to SP.

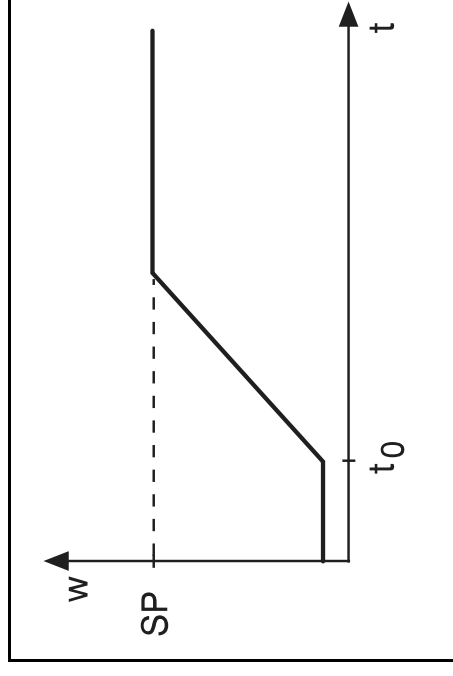

Action on sensor break

On sensor break the ramp function is interrupted. The outputs act as for overrange or underrange (can be configured). When the fault has been rectified, the controller accepts the current process value as ramp setpoint and continues the ramp function.

Action on power failure

When the supply is restored, the controller accepts the current process value as ramp setpoint and continues the ramp function with the set parameters.

Ramp stop

Activating the ramp stop via a logic input holds the ramp function. The setpoint display flashes. After the ramp stop has been de-activated, the ramp function continues with the ramp setpoint at the time of the ramp stop.

Re-starting the ramp

- * Re-start the ramp with  +  or via the logic input

Parameter	Value range	factory-set	Notes
rASd	0—999 digit/h or digit/min [†]	0	ramp gradient

1. In the display with one or two decimal places, the value range changes to 0.0 — 99.9 digit/h (digit/min.)

C113	Ramp function	X	X	X
	Ramp function off		0	
	Ramp function (time base: minutes)		5	
	Ramp function (time base: hours)		6	

 = factory setting X = position functionally not relevant

6.9 Programme controller

It is possible to implement a setpoint programme with up to 4 profile segments. The segment setpoints (SP00 — SP03) and the segment times (t00 — t03) are set at the operating level. The time base can be configured in seconds or minutes (max. segment time 9999 min.).

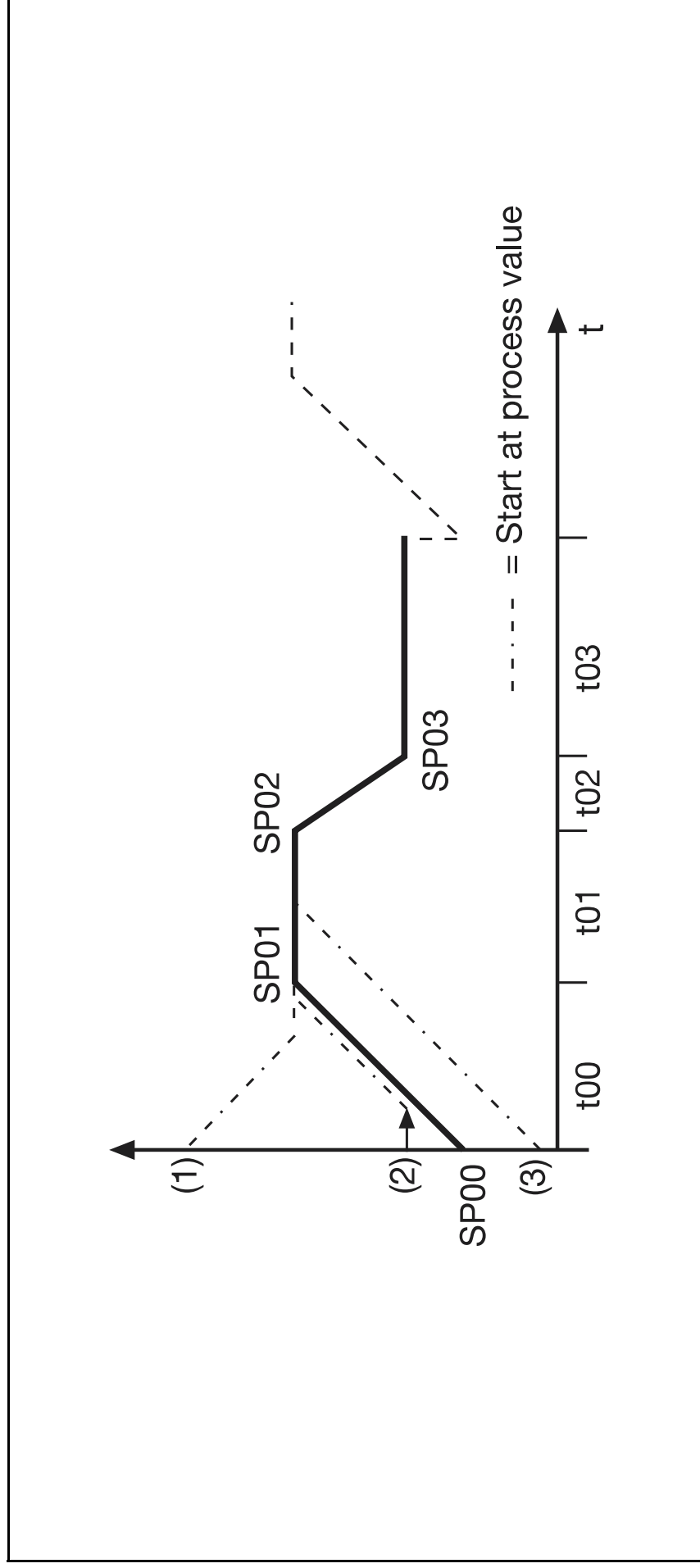

The programme starts at the process value, i. e. the profile is searched to find a setpoint which corresponds to the process value at the instant of start or power-on. ((1), (2), (3)). The profile then continues from this point. If the process value is outside the profile, a start is made at the first profile segment and the segment setpoint is then approached with the gradient of the first segment (positive or negative). The programme can either be run through once or repeated cyclically. In addition, a programme end signal can be output and the programme can be held.

⇒ Section 6.6 "Outputs"

Action on sensor break

On sensor break the programme is interrupted. The outputs act as for overrange or underrange (can be configured). When the fault has been rectified, the programme continues with the process value.



Action on power failure

When the supply is restored, the programme starts at the process value.

Programme stop

The programme is held by activating the programme stop via a logic input. The setpoint display flashes. After the programme stop has been de-activated, the programme continues with the setpoint at the time of the programme stop.

Re-starting the programme

* Re-start the programme with  +  or via the logic input

Programme function	X	X	X	X
Programme controller off				
Programme controller (timebase: seconds)				
Programme controller (timebase: seconds; cyclic)				
Programme controller (timebase: minutes)				
Programme controller (timebase: minutes; cyclic)				

■ = factory setting X = position functionally not relevant

6.10 Self-optimisation

Self-optimisation determines the controller parameters for PID or PI controllers.

The following controller parameters are defined: r_t , d_t , P_b1 , P_b2 , C_y1 , C_y2 , dF

If there is a large deviation between process value and setpoint when SO is activated, a switching level is determined about which the process variable performs a forced oscillation during the SO procedure. The switching level is chosen so that the process value does not exceed the setpoint, if possible.

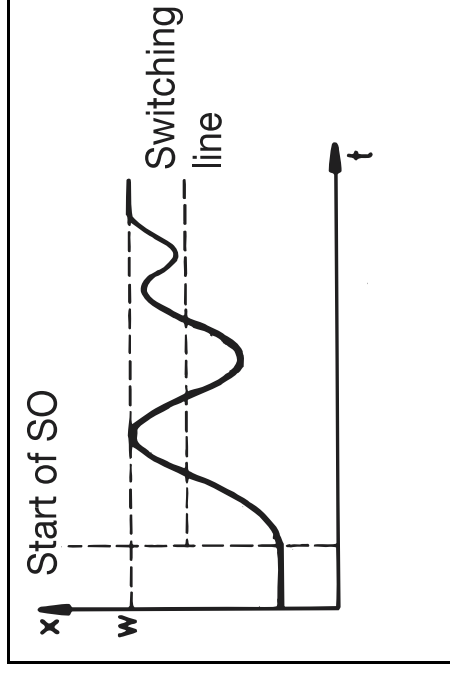

With a small deviation between setpoint and process value, e.g. when the control loop has stabilised, a forced oscillation about the setpoint is produced.

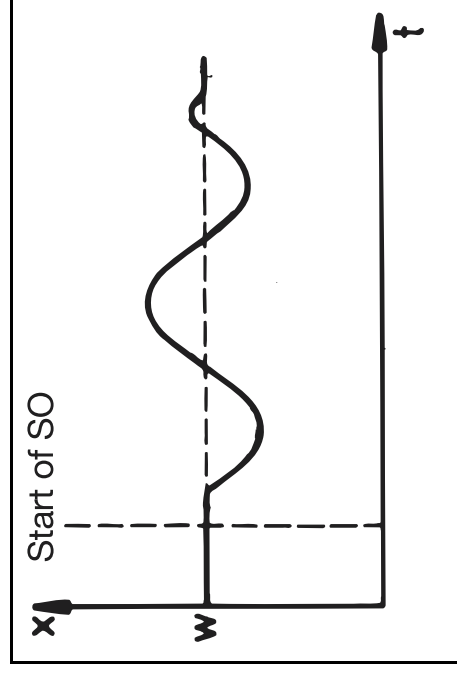

Starting self-optimisation

- * Start SO with **EXIT** (hold down key for at least 2 sec !)
- * Abort with **EXIT** (while self-optimisation is running)

If "tune" does not flash any longer, self-optimisation is terminated and the controller functions with the parameters which have been established.

- * Store the parameters with **EXIT** (Hold down key for at least 2 sec!)



Starting SO is not possible with active level inhibit.
The active parameter set is optimised.

With active ramp/programme function, the ramp/programme sequence is stopped during self-optimisation.

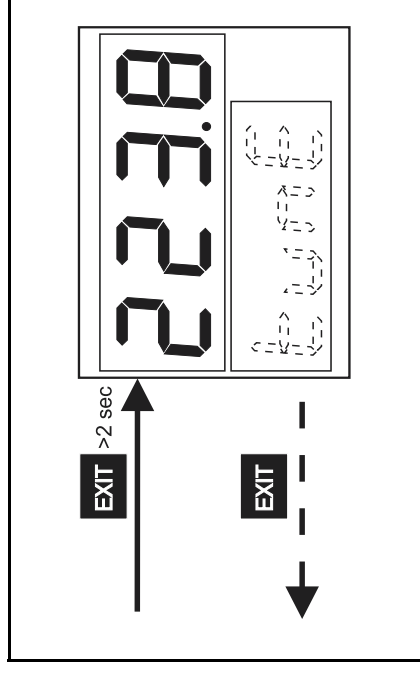

7 Appendix

7.1 Configuration code and parameter tables

C111

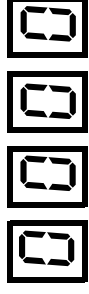

Process value input	
Pt 100	0
Pt 1000	1
Fe-Con L	2
NiCr-Ni K	3
Pt10Rh-Pt S	4
Pt13Rh-Pt R	5
Pt30Rh-Pt B	6
Cu-Con U	7
NiCrSi-NiSi N	8
Fe-Con J	9
0 — 20mA	A
4 — 20mA	b

Logic input 1 (BE1) and 2 (BE2)	BE1	BE2
no function	0	0
Key inhibit	1	1
Level inhibit	2	2
Programme/ramp stop	3	3
Programme/ramp start	4	4
Setpoint switching	5	5
Parameter set switching	6	6
Enabling the limit comparators	7	7
Output 4 (A4) and 5 (A5)	A4	A5
Controller output 1	8	8
Controller output 2	9	9
Limit comparator output 1	A	A
Limit comparator output 2	b	b
Programme end	C	C

■ = factory-set

8 7 1 4

Limit comparator 1 (LK1) and 2 (LK2)	LK1	LK2	Decimal places/ unit		Output signal on overrange
no function	0	0	XXXX / °C	0	Output 0%, LK1+2 OFF
lk 1 (process value input)	1	1	XXX.X / °C	1	Output 100%, LK1+2 OFF
lk 2 (process value input)	2	2	XX.XX / °C	2	Output -100%, LK1+2 OFF
lk 3 (process value input)	3	3	XXXX / °F	3	Output 0%, LK1+2 ON
lk 4 (process value input)	4	4	XXX.X / °F	4	Output 100%, LK1+2 ON
lk 5 (process value input)	5	5	XX.XX / °F	5	Output -100%, LK1+2 ON
lk 6 (process value input)	6	6			
lk 7 (process value input)	7	7			
lk 8 (process value input)	8	8			

■ = factory-set

C113

0013

Controller type	Programme function	Output 1 (K1; relay) and 2 (K2; relay)
1-setpt. controller O function	Programme controller/ ramp function off	no function
1-setpt. controller S function	Programme controller time base: seconds	Controller output 1
2-setpoint controller	Programme controller time base: seconds; cyclic	Controller output 2
Proportional controller with falling characteristic	Programme controller time base: minutes	Limit comparator output 1
Proportional controller with rising characteristic	Programme controller time base: minutes; cyclic	Limit comparator output 2
	Ramp function	Programme end
	Ramp function time base: minutes	
	Ramp function time base: hours	

■ = factory-set

C114

0 1 0 4

Geräteadresse		
Address 0	0	0
Address 1	0	1
.	.	.
.	.	.
Address 99	9	9

Schnittstellenparameter	
9600 baud, no parity	0
9600 baud, odd parity	1
9600 baud, even parity	2
4800 baud, no parity	3
4800 baud, odd parity	4
4800 baud, even parity	5

Ausgang 3 (K3; Relais)	K3
no function	0
Controller output (0...20mA/0...10V/switching)	1
Controller output (0...20mA/0...10V/switching)	2
Limit comparator output 1 (switching)	3
Limit comparator output 2 (switching)	4
Programme end (switching)	5
Controller output (4...20mA/2...10V)	6
Controller output (4...20mA/2...10V)	7
Process value input (0...20mA/0...10V)	8
Process value input (4...20mA/2...10V)	9

■ = factory-set

The parameters of the configuration level

Parameter	Value range	factory-set	Notes
SCL	-1999 to +9999 digit ¹	-50	Start value of value range for standard signals
SCH	-1999 to +9999 digit ¹	250	End value of value range for standard signals
SPL	-1999 to +9999 digit ¹	-40	Display start with external setpoint input
SPH	-1999 to +9999 digit ¹	600	Display end with external setpoint input
OFFS	-1999 to +9999 digit ¹	0	Process value correction (offset)
HySt	-1999 to +9999 digit ¹	1	Switching differential of limit comparators

1. On displays with one or two decimal places the value range and the factory setting change accordingly (e. g. 1 decimal place → value range: -199.9 to +999.9).

Parameter level

Parameter	Value range	factory-set	Notes
AL 1	-1999 to +9999 digit ¹	2	Limit for limit comparator 1
AL 2	-1999 to +9999 digit ¹	80	Limit for limit comparator 2
Pb 1	0—9999 digit ¹	0	Proportional band 1 (controller output 1)
Pb 2	0—9999 digit ¹	0	Proportional band 2 (controller output 2)
dt	0—9999 sec	80 s	Derivative time
rt	0—9999 sec	350 s	Reset time
Cy 1	0.5—999.9 sec	20.0 s	Switching cycle time 1 (controller output 1)
Cy 2	0.5—999.9 sec	20.0 s	Switching cycle time 2 (controller output 2)
db	0—1000 digit ¹	0.0	Contact spacing
HYS 1	0—9999 digit ¹	1.0	Switching differential 1 (controller output 1)
HYS 2	0—9999 digit ¹	1.0	Switching differential 2 (controller output 2)
Y0	-100—100%	0%	Working point
Y1	0—100%	100%	Output limitation: maximum output
Y2	-100 to +100%	-100%	Output limitation: minimum output
dF	0.0—100.0 sec	0.6 s	Filter time constant for adaptation
raSd	0—999 digit ¹	0	Ramp gradient

1. On displays with one or two decimal places the value range and the factory setting change accordingly (e. g. 1 decimal place → value range: -199.9 to +999.9)

7.2 Alarm messages

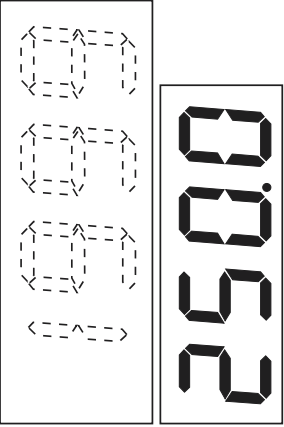
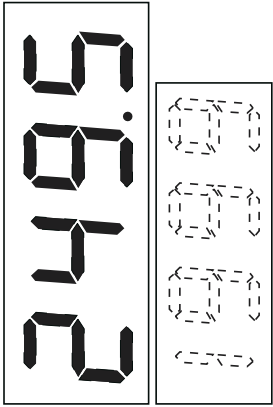
Display	Description	Cause/response
	<p>The process value display flashes "1999".</p> <p>The setpoint display indicates the active setpoint</p>	<p>Over/underrange of the process value. Controller and limit comparators referred to the process value input act in accordance with the configuration of the outputs.</p>
	<p>The process value display indicates the process value.</p> <p>The setpoint display flashes "1999".</p>	<p>Over/underrange of the external setpoint. Limit comparators referred to the input for the external setpoint act according to the configuration of the outputs.</p>

The following events come under the heading over/underrange:

- Sensor break/short-circuit
- Measurement is outside the control range of the connected sensor
- Display overflow

7.3 Technical data

Inputs

These values include the linearisation tolerances.

Transducer	Control range	Measurement accuracy/ Ambient temperature error	Measurement circuit	
			Sensor break	Short-circuit
Process value input				
Pt 100 ²	-200 +850°C	≤ 0.1% / ≤ 25 ppm / °C	X	X
Pt 1000 ²	-200 +850°C	≤ 0.1% / ≤ 25 ppm / °C	X	X
Fe-Con L ³	-200 +900°C	≤ 0.25% / ≤ 100 ppm / °C	X	-
Fe-Con J ³	-200 +1200°C	≤ 0.25% / ≤ 100 ppm / °C	X	-
NiCr-Ni K ³	-200 +1372°C	≤ 0.25% / ≤ 100 ppm / °C	X	-
Cu-Con U ³	-200 +600°C	≤ 0.25% / ≤ 100 ppm / °C	X	-
NiCrSi-NiSi N ³	-100 +1300°C	≤ 0.25% / ≤ 100 ppm / °C	X	-
Pt10Rh-Pt S ³	0 — 1768°C	≤ 0.25% / ≤ 100 ppm / °C	X	-
Pt13Rh-Pt R ³	0 — 1768°C	≤ 0.25% / ≤ 100 ppm / °C	X	-
Pt30Rh-Pt6Rh B ³	0 — 1820°C	≤ 0.25% / ≤ 100 ppm / °C ⁴	X	-
0 — 20mA ⁵	scalable	≤ 0.1% / ≤ 100 ppm / °C	-	-
4 — 20mA ⁵	scalable	≤ 0.1% / ≤ 100 ppm / °C	X	X

1. X=recognised, – = not recognised
The outputs move to a defined status.
2. Pt 100, Pt 1000 in 2- or 3-wire circuit
Lead compensation:
Not required for 3-wire circuit. When used with a resistance thermometer in 2-wire circuit, lead compensation can be provided by an external lead compensation resistor.
($R_{\text{comp}} = R_{\text{line}}$). In addition, the lead resistance can be compensated in software through process value correction.
3. Temperature compensation: internal
4. Within the range of 300 — 1820 °C
5. Voltage drop Δu_e less than 1 V

Outputs

3 relay outputs, 2 logic outputs

1. Relay outputs **K1/K2**: n.o. (make) contact)

Rating 3A, 250 V AC on resistive load

Contact life more than $5 \cdot 10^5$ operations at rated load

1b. Relay output **K3**: (SPST) Contact)

0/5V

R_{load} 250 Ω min.

2. Logic outputs:

General controller data

A/D converter: resolution better than 15bit

Controller type: can be configured as single / double setpoint or proportional controller

Sampling time: 210msec

250 msec on programme controller

Data back-up: EEPROM

Supply: 110 — 240V +10/-15% AC 48 — 63Hz

Power consumption: 5VA approx.

Electrical connection: through screw terminals for wires up to 1.5mm² and core end sleeves

Permitted ambient temperature range: 0 to + 55 °C

Permitted storage temperature range: -40 to + 70 °C

Climatic conditions: relative humidity not to exceed 75%, no condensation

Protection: to EN 60 529
front IP65, rear IP20

Electrical safety
to EN 61 010
clearances and creepage distances for
- overvoltage category II
- pollution degree 2

Electromagnetic compatibility
to NAMUR recommendation NE21, EN 50 081 Part 1, EN 50 082 Part 2

Housing
for flush panel mounting to DIN 43 700, base material PC, with plug-in controller chassis

Operating position: unrestricted

Weight: 140g

Tyco offices

België / Belgique

Tyco Thermal Controls
Staatsbaan 4A
3210 Lubbeek
Tel. (016) 213 511
Fax (016) 213 610

Česká Republika

Raychem HTS s.r.o.
Novodvorská 82
14200 Praha 4
Phone (02) 41 00 92 15
Fax (02) 41 00 92 19

Danmark

Tyco Thermal Controls Nordic AB
Stationsvägen 4
S-430 63 Hindås
Tel. 70 11 04 00
Fax 70 11 04 01

Deutschland

Tyco Thermal Controls GmbH
Kölner Strasse 46
57555 Mundersbach
Tel. 0800 1818205
Fax 0800 1818204

España

Tracelec
C/Josep V. Foix 10
Apdo. 1326-43080
43007 Tarragona
Tel. (34) 977 290 039
Fax (34) 977 290 032

France

Tyco thermal Controls SA
B.P. 738
95004 Cergy-Pontoise Cedex
Tél. 0800 906045
Fax 0800 906003

Hrvatska

ELGRI d.o.o.
S. Mihalica 2
10000 Zagreb
Tel. (1) 6050188
Fax (1) 6050187

Italia

Tyco Electronics Raychem SPA
Centro Direzionale Milanofiori
Palazzo E5
20090 Assago, Milano
Tel. (02) 57 57 61
Fax (02) 57 57 62 01

Magyarország

Raychem Ges.m.b.H.
Magyarországi Közvetlen Képviselő
Grassalkovich ut 255.
1239 Budapest
Tel. (1) 289 20 40
Fax (1) 289 20 45

Nederland

Tyco Thermal Controls b.v.
Van Heuven Goedhartlaan 121
1181 KK Amstelveen
Tel. 0800 0224978
Fax 0800 0224993

Norge

Tyco Thermal Controls Norway AS
Malerhaugveien 25
Postboks 6076 - Etterstad
0602 Oslo
Tel. +47 66 81 79 90
Fax +47 66 80 83 92

Österreich

Tyco Thermal Controls N.V. Lubbeek
Office Wien
Brown-Boveri Strasse 6/14
2351 Wiener Neudorf
Tel. (0 22 36) 86 00 77
Fax (0 22 36) 86 00 77-5

Polska

Raychem Polska Sp. z.o.o.
Tyco Thermal Controls
ul. Farbiarska 69 C
02-862 Warszawa
Tel. (022) 54 52 950
Fax (022) 54 52 951

Schweiz / Suisse

Tyco Thermal Controls N.V.
Office Baar
Haldenstrasse 5
Postfach 2724
6342 Baar
Tel. (041) 766 30 80
Fax (041) 733 30 81

Suomi

Tyco Thermal Controls Nordic AB
Stationsvägen 4
S-430 63 Hindås
Puh. 0800 11 67 99
Telekopio 0800 11 86 74

Sverige

Tyco Thermal Controls Nordic AB
Stationsvägen 4
S-430 63 Hindås
Tel. 0301-228 00
Fax 0301-212-10

United Kingdom

Tyco Thermal Controls (UK) Ltd
3 Rutherford Road,
Stephenson Industrial Estate
Washington, Tyne & Wear
NE37 3HX, United Kingdom
Phone 0800 96 90 13
Fax 0800 96 86 24

ROSSIÁ i drugie strany SNG

RAJXEM

125315, g. Moskva
Leningradskij prospekt, dom 72,
ofis 807
Tel.: (095) 7211888
Faks: (095) 7211891

www.tycothermal.com

